

On Primary / Secondary installs the TX must be powered from a non monitored source i.e. any power output on the Matrix III other than the 12VDC supply on the "UL Sensor NC" connector.

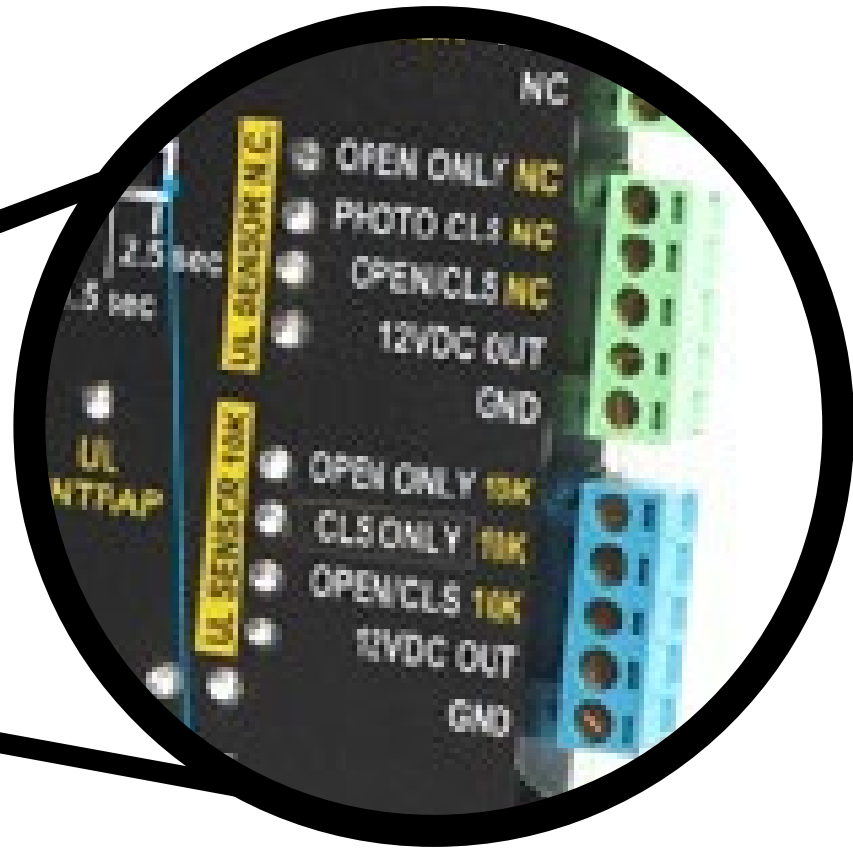

### 66HD Photo Eye

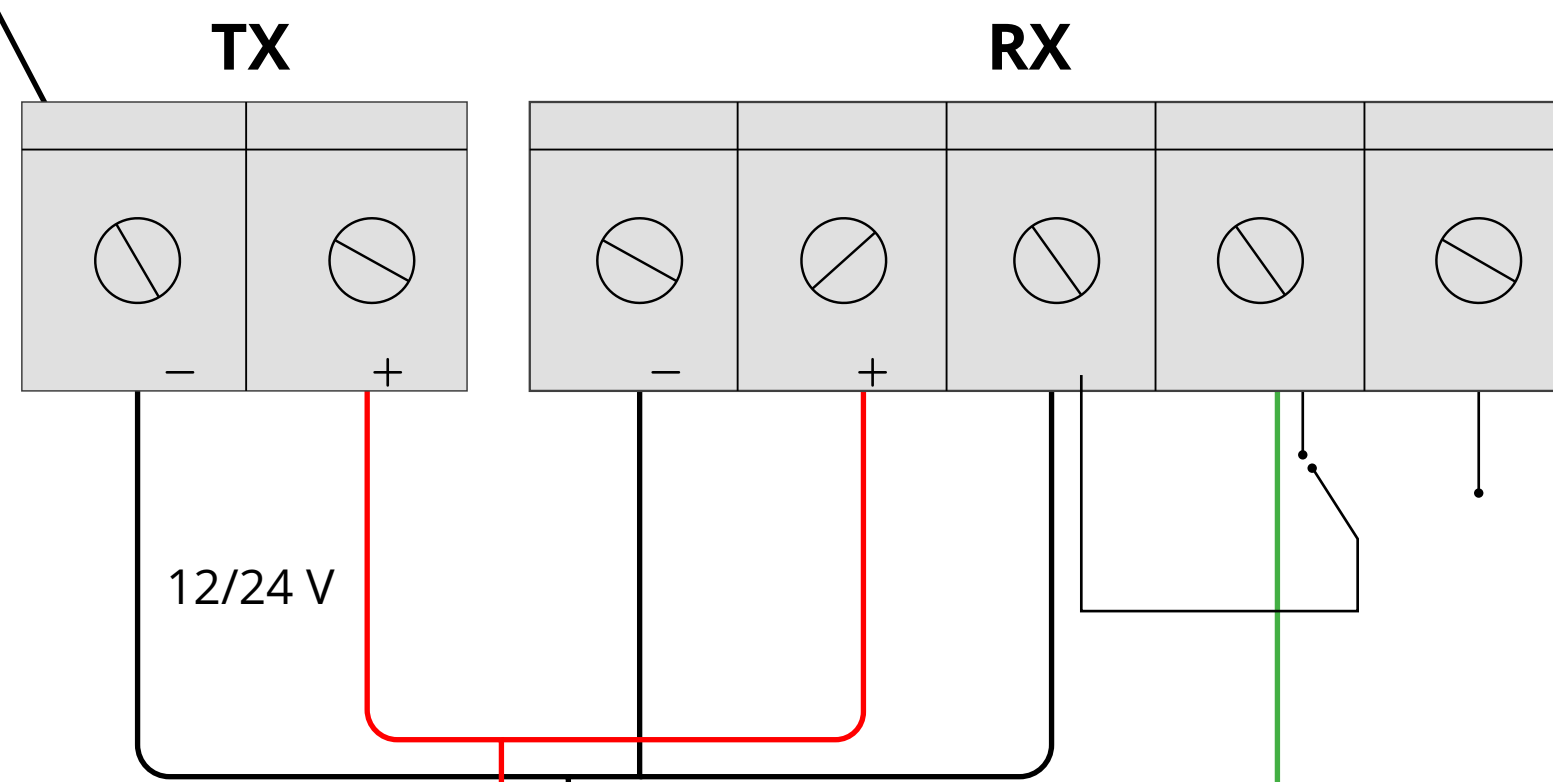

UL 325 RECOGNIZED COMPONENT

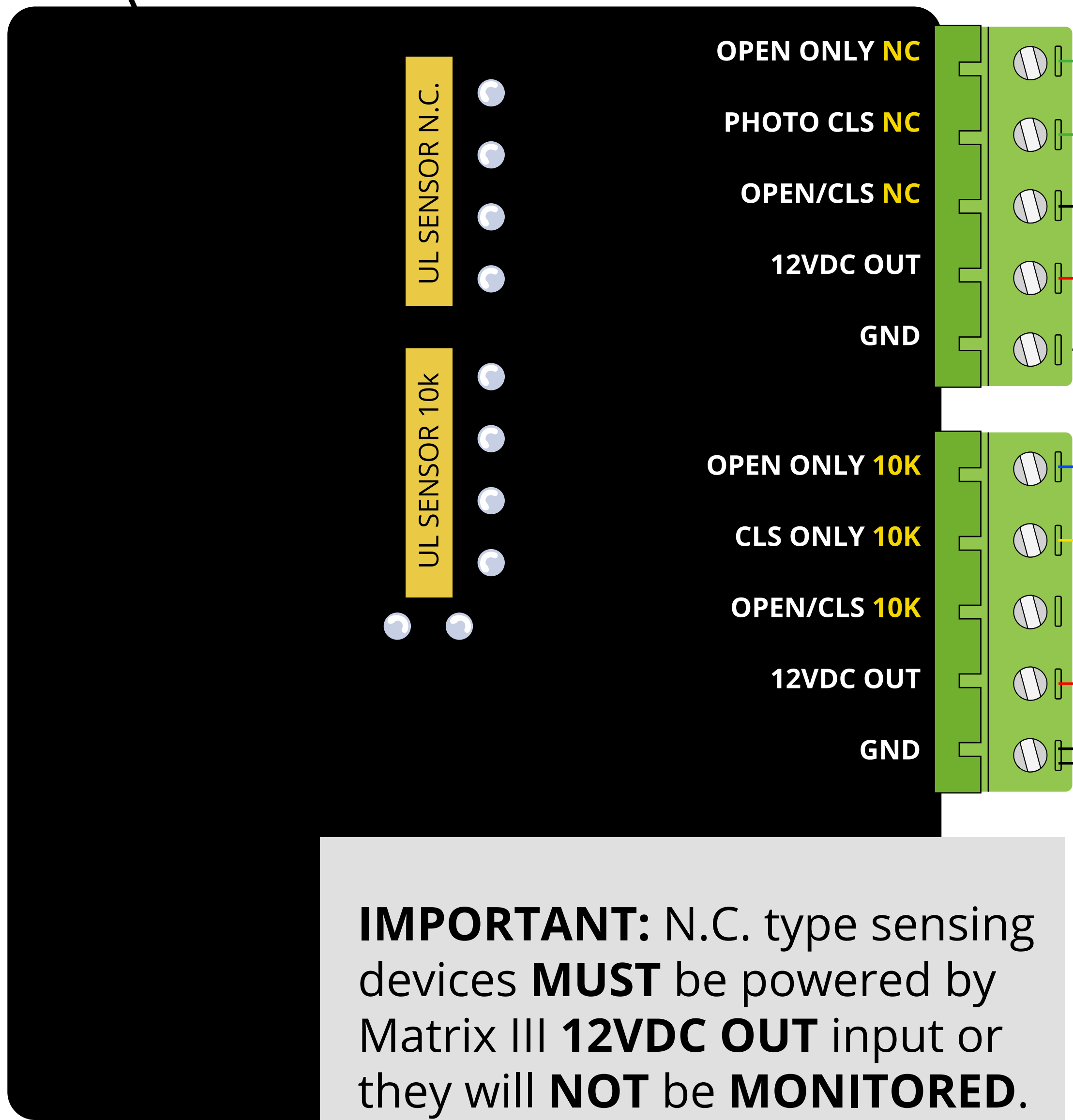

**IMPORTANT:** N.C. type sensing devices **MUST** be powered by Matrix III **12VDC OUT** input or they will **NOT** be **MONITORED**.

Factory Learned Input  
Factory Learned Input  
Additional Unlearned Input  
12VDC OUT monitored

Unlearned Input  
Unlearned Input  
Additional Unlearned Input

### 50LR Photo Eye

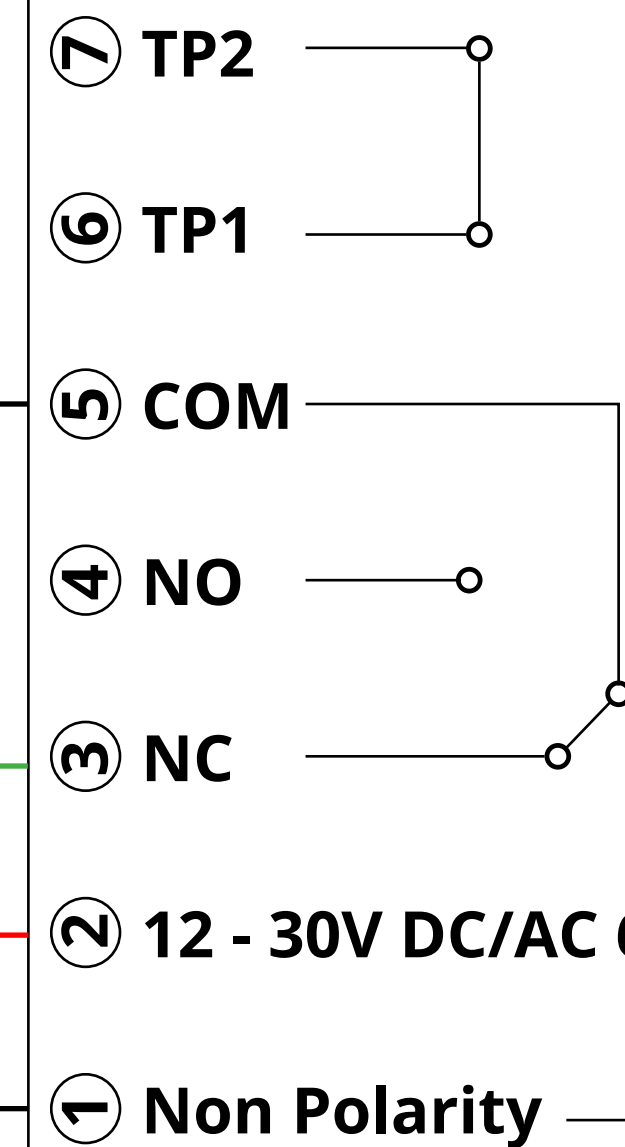

To learn devices press and hold stop and open until the beeping begins, release, confirm that your input LED's are solid blue, then press stop. If input LED's flash after programming, communication has not been established. Check your wires and device.



UL 325 RECOGNIZED COMPONENT

### RE KIT RECEIVER

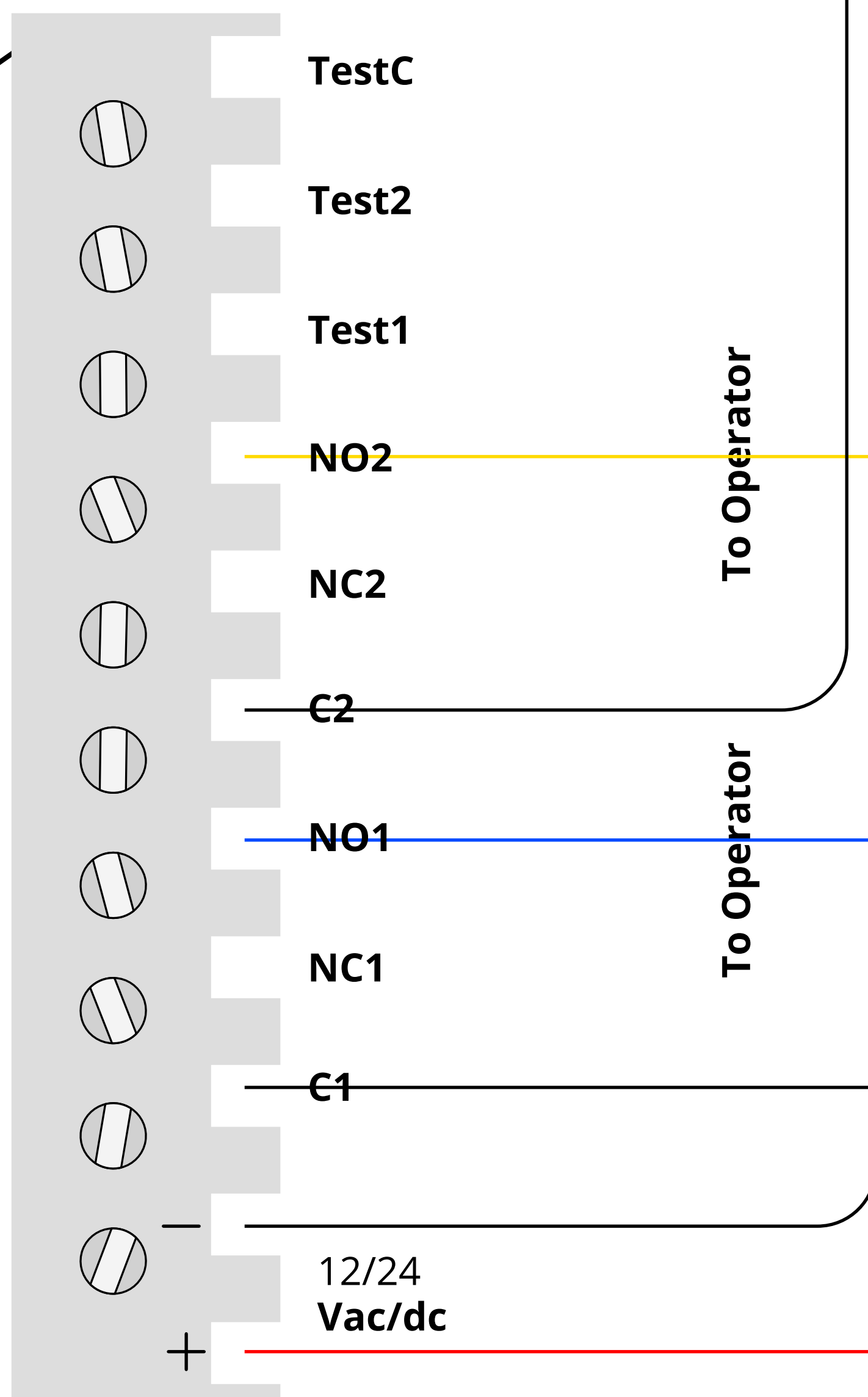

To Operator  
To Operator

