

PRMP-H

Wiegand/ RS485 Mullion Card Reader



FEATURES

- Non-Scratch Surface
- Desfire, HID & EM
- Touch Sensor Keypad
- Metal Back Plate
- Non-Drop Bottom Screw
- Indoor & Outdoor use
- Tamper Protection
- Mullion Card Reader/Keypad

SPECIFICATIONS

Output:	Option of 26-Bit Wiegand or OSDP
Keypad bit burst	4, 8 or 10 bit bursts
IP Rating:	IP65 Certified
Wiring Distance:	492FT (22 AWG with shielded cable)
Temperature Rating:	-22°F to 158°F
Proximity Card Reader:	ISO14443A-Desfire
Read Range:	2-5 cm
Operating Voltage:	10V-15VDC
Dimensions:	5-5/8(L) x 1-3/4(W) x 7/8(D) inches
Weight:	5-3/4 oz
Operating Current:	160mA (max)

Mounting:

1. Install the metal plate on the wall with two or four screws, depending on the type of gang box used.
2. Clip the cover onto the upper edge of the plate, then push in the bottom to align the non-dropout screw with the metal tab (as shown in the diagram).
3. Tighten the secure non-dropout screw located under the reader to secure it to the back plate.

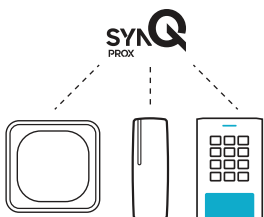
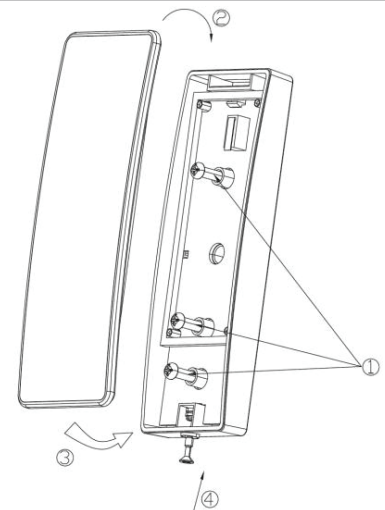

MOBILE CREDENTIALS AVAILABLE
USING SYNQ

Ask your sales rep about SynQ today!



240 South 3850 West, Suite B
Salt Lake City, UT 84120
866-975-0101 | 866-975-0044 Fax
www.transmittersolutions.com

All items are trademarks of their respective holders.

Requirement:

1. Linear DC Power Supply
2. 22AWG shielded cable
3. Single-point ground required (as shown in wiring diagram)

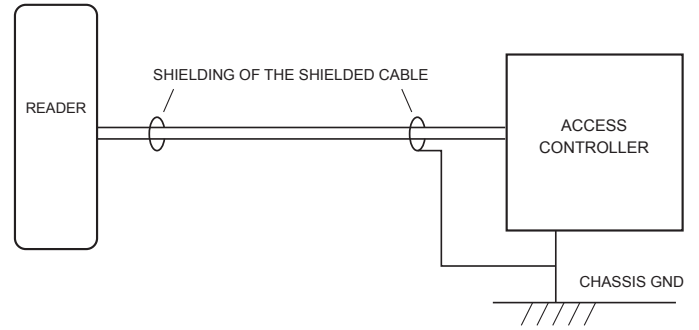

Wiring Guide:

Color	Label	Description
Red	+12V dc	Power Supply to the reader
Black	GND	Signal GND
Green	Data0	Wiegand Output data, D0
White	Data1	Wiegand Output data, D1
Yellow	Red	RED LED control, active low
Blue	Green	Green LED control, active low
Brown	Buzzer	Buzzer input, active low
Orange	Tamper	Tamper output (open collector, Active low, max 100mA)
Purple	Doorbell	Door bell output (open collector, +5Vdc output ≤ 5mA)
Grey	RS485A	RS485A
Yellow & Green	RS485B	RS485B

Power Up Sequences:

1. This is a two-technology contactless smart card reader. When the card reader starts, the blue backlight lights up and makes a sound, indicating that the card reader enters the working state
2. Swipe card, blue LED light flashing once, buzzer beep once.
3. The data is transmitted to the controller during the swipe, and the backlight status (original state, flashing, or green or red) depends on the different LED inputs.
4. Keyboard reader, each time the key button, the backlight will blink once, buzzer will beep a sound. The keyboard output format is 26 bits by default.

Physical Dimension:

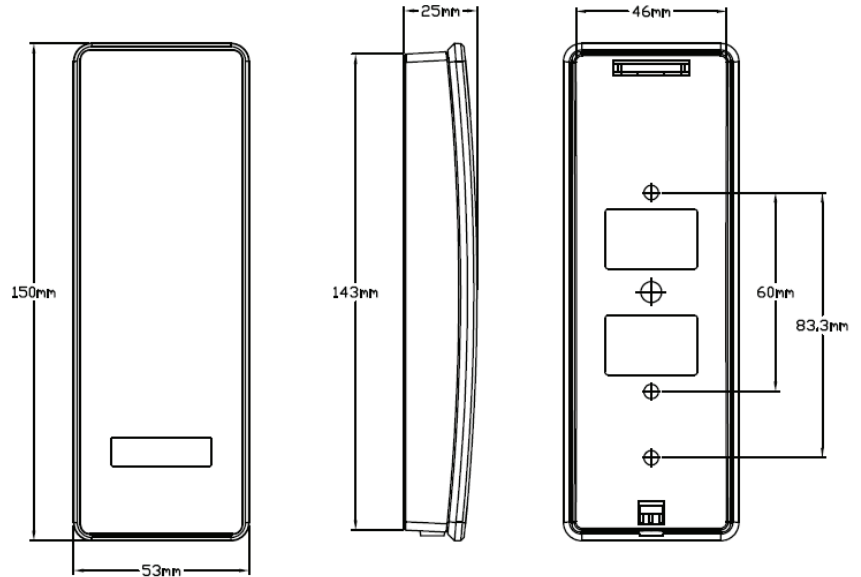

Trouble Shooting:

Trouble List	Solution
No Response when Power Up	<ul style="list-style-type: none"> • Disconnect the power and confirm that the power supply cable is correctly connected (See "Wiring" above). • Check the input voltage is sufficient (See "Specifications" above).
Auto Restart	<ul style="list-style-type: none"> • Check the input voltage is sufficient (See "Specifications" above).
Cannot read card number correctly	<ul style="list-style-type: none"> • Check the format setting on the controller if it is the same as the card format. Use approved card (known format and Facility Code) to test. • Check if the shield cable is correctly connected to Chassis Ground at ONE point only.
Reader beeps but No card data info	<ul style="list-style-type: none"> • Check if data 0 & data 1 cable is correctly connected (See "Wiring" above). • Check the input voltage at the card reader end is correct (See "Specifications" above).
Buzzer error	<ul style="list-style-type: none"> • Check if the buzzer cable is correctly connected (See "Wiring" above).
Back Lit Error	<ul style="list-style-type: none"> • Check the LED cable is correctly connected (See "Wiring" above). • Use Default Configuration Card to set it back to normal.
Keypad No Response	<ul style="list-style-type: none"> • Power off reader for 5 seconds and power on again